

# Shrink Banding Tunnel

# PP-1230 SBT

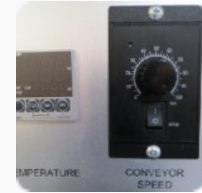

Variable Air Velocity Control



Variable Speed Conveyor

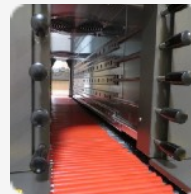

Close Roller Spacing to Transport Unstable Products



Adjustable Air Flow Dampeners to Concentrate Air Flow in Specific Locations on Package

## OVERVIEW

This versatile tunnel can be used for a wide variety of applications such as tamper evident neck bands, full body shrink sleeves for pill bottles, jars, food and beverage containers and other similar containers. The PP-1230 SBT is a proven workhorse with thousands of machines in the field successfully running since 1993. Our 25 plus years of experience as the industry leader in manufacturing Shrink Banding Tunnels will give you the peace of mind knowing you have purchased the best machine available on the market today!

## KEY FEATURES

- Variable Air Velocity Control
- Variable Speed Conveyor
- Dual 1HP Blower Motors
- Adjustable Air Flow Dampeners
- Close Roller Spacing
- Locking Casters
- Leveling Pads

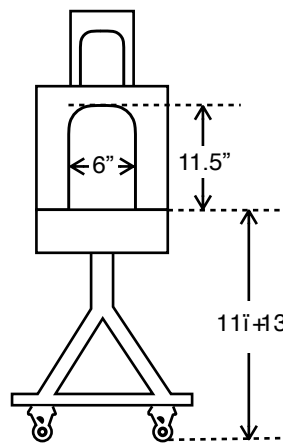
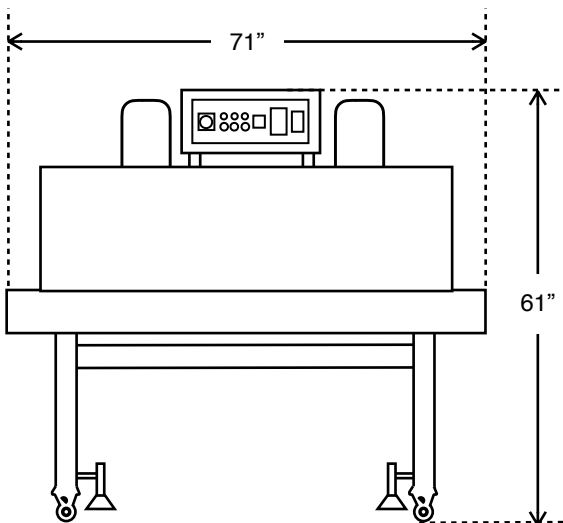

Model #	Tunnel Height	Tunnel Width	Conveyor Speed	Weight	Power
PP-1230 SBT	11.5"	6"	Variable 0-70 FPM	462	220V / 3 Phase / 40 Amp