

Lazy Susan Product Accumulator

Model:

PP-36LS

Great for accumulating smaller products and packages.



Production Line Efficiency

If you're looking for a reliable and convenient way to accumulate smaller packages and shrink wrapped products as they leave your production line, consider using the **PP-36LS Lazy Susan Product Accumulating Turntable**. This particular model is 36" in diameter and can be set up to turn at a speed of 0-12 RPM. This is a nice alternative to a conveyor, where smaller items would normally fall through the cracks. The **PP-36LS** can be plugged into any standard 110-volt outlet. The accumulator table sits on top of high-quality rollers. The adjustable leveling bolts allow you to match any conveyor line height. The spinning movement is smooth and even.

Options:

Also available in **stainless steel.*

Turntables available in **36", 48" or 60" diameter.*

STANDARD FEATURES

- Turntable speed adjusts from 0 to 12 RPM
- Plugs in to any 110 V outlet
- Includes adjustable leveling screws
- Holds up to 200 lbs. of product
- 3" deep table top



DIMENSIONS

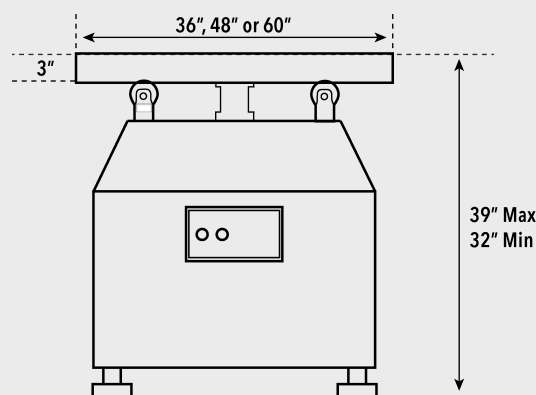

Place the **PP-36LS** at the end of any production line or shrink tunnel to catch finished products.

SPECIFICATIONS

All Models:	PP-36LS	PP-48LS	PP-60LS
Turntable Diameter	36"	48"	60"
Turntable Depth	3"	3"	4"
Power	110v 5 amp	110v 5 amp	110v 10 amp
Finish	Standard	Standard	Standard
Shipping Weight	250 lbs	300 lbs	375 lbs
RPM	0-12	0-10	0-10
Stainless Steel Available?	Yes	Yes	Yes

