

Semi Automatic L'Sealer

Entry-level, light duty film sealing machine for heat-shrinkable applications

Model:

PP-1519LMC



The **Preferred Pack Model PP-1519LMC L'Sealer** (15"W x 19"L Seal Area), an entry-level, light duty L'Sealer with Micro Knife Seal Technology you will get years of use with minimal repairs. This machine is capable of operating at speeds of 8-12 PPM.

The **Micro Knife Sealing Technology** is the most advanced seal system available on a semi-automatic L'Sealer. This Teflon-coated sealing blade is guaranteed not to break for 1 full year or we will replace at no cost. Teflon coating allows the film to seal with minimal smoke or residue and produces straight seals with no pinholes. It is simply the best seal system on the market today.

Our 20 plus years of experience as the industry leader in manufacturing semi and fully automatic L'Sealers will give you the peace of mind knowing you have purchased the best machine available on the market today! Our mission is to provide our customers with the latest technology and a user friendly machine that is efficient and easy to maintain. The Preferred Pack brand will give you the lowest total cost of ownership available in the market. We partner with a nationwide network of highly trained packaging distributors in order to better serve our customers. This partnership provides a support structure to ensure a smooth startup, reliable local service and a long term return on your machinery investment.

STANDARD FEATURES INCLUDE:

- Micro Knife Band Ribbon Seal
- Motorized Discharge Conveyor
- Stainless Steel Compensator
- Seal and Magnet Timer
- Dual Magnet Hold Down
- Stainless Steel Film Clamps
- Pin Wheel Hole Punch
- Discharge Conveyor Timer
- Locking Casters
- Powder Coated Frame
- Transition Rollers on Discharge Conveyor





Compensator Assembly keeps sealing temperature from overheating.



The **Micro Knife Sealing Technology** is the most advanced seal system available on a semi-automatic L'Sealer. This Teflon-coated sealing blade is guaranteed not to break for 1 full year or we will replace at no cost. Teflon coating allows the film to seal with minimal smoke or residue and produces straight seals with no pinholes. It is simply the best seal system on the market today.



On/Off Switch **Conveyor Timer** **Seal Timer** **Magnet Timer**

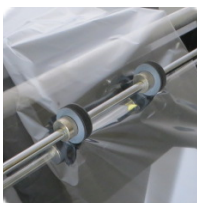

Pinwheel Hole Punch



20" Film Cradle with Roll Brake

DIMENSIONS

Max Film Width: 20"
Seal Dimensions L-W: 19" x 15"
Machine Dimensions L-W-H: 64" x 27" x 39"
Crated Dimensions L-W-H: 42" x 26" x 48"

POWER

Voltage: 110
 1 Phase 15AMP Dedicated

NET WEIGHT

331lbs (150kgs)

SHIPPING WEIGHT

331lbs (150kgs)

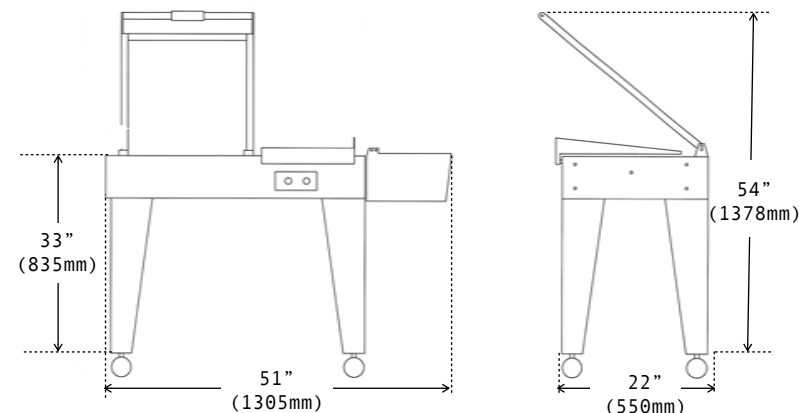

Additional Models

PP-1519L

Entry-level machine without magnet hold down or discharge conveyor. All other features are identical to model PP-1519LMC.



PP-1519LM

Same as PP-1519L with the addition of a magnetic arm hold down.

